



CAUTION: CAREFULLY READ INSTRUCTIONS BEFORE PROCEEDING. NOT LEGAL FOR SALE OR USE IN CALIFORNIA OR ON ANY POLLUTION CONTROLLED VEHICLES.

INTRODUCTION

Daytona Twin Tec can supply specially programmed VRFI units with firmware that implements speed-density control for turbo/supercharged applications (refer to Appendix A for details). Required electrical modifications to the motorcycle include installation of a Delphi 3-bar (40-304 kPa) MAP sensor and new intake air temperature (IAT). For engine setup and mapping, PC Link VRFI software version 14.0 or higher is required. For real time display and downloading logged data, VRFI Log software version 14.0 or higher is required. Firmware and software files are available for download from our website.

Installation requires an initial setup file. Daytona Twin Tec will assist customers in preparing an initial setup file. To determine required fuel injector flow ratings and setup parameters, a fuel calculator in the form of an Excel spreadsheet is also available for download from the same page on our website (refer to Appendix B for details). The calculator spreadsheet includes a table with typical brake specific fuel consumption (BSFC) and target Lambda values for various fuels.

INSTALLATION

1. Replace the OE MAP sensor with a Delphi 3-bar (40-304 kPa) MAP sensor P/N 12223861. Aftermarket replacement parts are available from Wells (P/N SU504 sold by Autozone at www.autozone.com) and Standard Motor Products (P/N AS210 sold by RockAuto at www.rockauto.com).
2. The Delphi 3-bar MAP sensor is a full size unit that will have to be remotely mounted and connected to the intake manifold with an appropriate vacuum hose. The full size MAP sensor also uses a different Delphi connector housing (P/N 12015796), male terminals (P/N 12089040-L), and seals (P/N 12015323). These parts are available from Mouser Electronics at www.mouser.com. The pinout is the same as the OE MAP sensor. Pin A (black/white) is ground, pin B (purple/white) is sensor signal, and pin C (red/white) is +5 volt power.

3. The intake air temperature (IAT) sensor must be relocated from the air box to the intake manifold (after the super/turbocharger and any intercooler). The OE snap-in IAT sensor is not suitable. Suggested aftermarket parts include Intermotor AX100 sold by RockAuto and the Bosch Motorsport NTC M12-LI P/N 0 280 130 039.
4. The Bosch LSU 4.2 wide-band exhaust gas oxygen sensors used with the VRFI system are rated for a maximum hexagon temperature of 570° C (1050° F) with brief excursions allowed to 630° C (1170° F). Use an infrared thermometer to verify that these temperature ratings are not exceeded during worst case operation at wide open throttle.
5. If the fuel pressure regulator is replaced, you must use a unit referenced to manifold pressure so that the injectors will see a constant fuel pressure differential. One possible part is the Bosch Motorsport Mini 5 P/N 0 280 B02 722-02. This is a 5-bar (73.5 psi) unit.
6. In most case, higher flow fuel injectors will be required. Sources for fuel injectors include Marren Fuel Injection (www.injector.com) and RC Engineering (www.rceng.com).

PC LINK VRFI SOFTWARE

Version 14.0 and higher PC Link software implements the special features required for 300 kPa speed-density control including ignition advance table with 0-300 kPa range, volumetric efficiency (VE) table in place of Alpha-N main fuel table, manual entry of injector base pulse width for very high output engines or alternate fuels (in place of automatic calculation based on engine horsepower), and use of Lambda fuel calibrations (in place of gasoline air/fuel ratio units).

Implementation of the special features described above is controlled by a configuration file that is loaded into the program folder during installation. You may have to edit some options in the configuration files for your application. You can use any text editor, such as Notepad or Wordpad. The PC Link VRFI configuration file name is PC_Link_VRFI.cfg. The configuration section is near the end of the file and starts with a comment line and then has four entries:

!configuration statements section

MAP3Bar_True (selects 3-bar MAP sensor mode)

ManualBaseInjPW_True (allows manual entry of base injector pulse width; change to ManualBaseInjPW_False for automatic calculation)

SpeedDensity_True (selects speed-density mode)

LambdaCal_True (selects Lambda based fuel calibration; leave as-is or change to LambdaCal_False if you prefer gasoline AFR units)

For all boosted applications, you should set the configuration file statements to include: MAP3Bar_True, ManualBaseInjPW_True, and SpeedDensity_True. Use the Excel fuel calculator spreadsheet mentioned in the introductory section for calculating the value for base injector pulse width. This value is entered under Module Parameters. Note that base injector pulse width controls overall fuel scaling within the system.

Note that H-D® has changed to Lambda based calibrations. There is no actual change to engine operation or values saved in the files, just the table display changes to Lambda values. For gasoline, $\text{Lambda} = \text{AFR}/14.69$.

Some special considerations apply for using wide-band exhaust gas oxygen sensors in super/turbocharged applications. Boost pressure combined with some camshaft profiles may cause unburned air-fuel mixture to be forced into the exhaust system during the overlap period when the intake and exhaust valve are both open. This will cause an overly rich air/fuel ratio (AFR) indication. Consequently, the target AFR values in the AFR table must be made correspondingly richer in order for closed loop AFR control to function properly. To minimize this effect, we suggest choosing a camshaft profile with minimum overlap.

For turbocharged engines, additional considerations apply. In automotive applications, the exhaust gas sensors are typically located downstream of the turbo. In a V-twin engine, the sensors for the front and rear cylinders are near the heads and upstream of the turbo. The exhaust back pressure affects the sensor readings and this effect must be taken into consideration. We suggest measuring the actual exhaust back pressure at wide open throttle.

Section 10.6 of the Bosch LSU 4.2 specifications (available for download at www.daytona-sensors.com/download/Bosch_LSU4.pdf) gives the pressure dependency of the sensor signal. At positive pressures, the sensor will read somewhat richer. Consequently, the wide open throttle (WOT) Lambda command values in the AFR table must be made correspondingly richer in order for closed loop AFR control to function properly. Table 1 shows the effect and the required correction. Consult our tech support for more details.

Table 1 – Lambda Correction

Exhaust Back Pressure (PSIG)	5	10	15
Correction Factor	.93	.89	.86
Typical Uncorrected WOT Lambda Command	.85	.85	.85
Corrected WOT Lambda Command	.79	.75	.73

We can help you prepare an appropriate setup file to upload into the VRFI system. Contact our tech support for details. A setup file for a similar normally aspirated engine can be used as a starting point. The advance table requires edits to retard timing under boost pressure conditions. The VE table is based on initial estimates or available logged data and will then automatically be corrected during the auto-tuning process. With the exceptions noted above, you can use the general installation and tuning steps outlined in the standard VRFI Gen 4 Installation & Tuning Manual. All references to the Alpha-N table should be replaced with the VE table.

VRFI LOG SOFTWARE

Version 14.0 and higher VRFI Log software implements the special features required for 300 kPa speed-density control including an extended range for real time and chart display of MAP values and the option to display Lambda values in place of gasoline air/fuel ratio units.

Implementation of the special features described above is controlled by a configuration file that is loaded into the program folder during installation. You may have to edit some options in the configuration files for your application. You can use any text editor, such as Notepad or Wordpad. The VRFI Log configuration file

name is VRFI_Log.cfg. The configuration section is near the end of the file and starts with a comment line and then has two entries:

!configuration statements section

MAP3Bar_True (selects 3-bar MAP sensor mode)

LambdaCal_True (when set to false, air/fuel ratio units are gasoline AFR values. When set to true, you can select Lambda or gasoline AFR units on the main menu using the Edit Units Selection command)

All other aspects of VRFI Log software remain unchanged.

APPENDIX A – AFR CONTROL LOOP

The output of the AFR control loop is injector pulse width. A higher pulse width causes more fuel to be injected and decreases the AFR towards a rich condition.

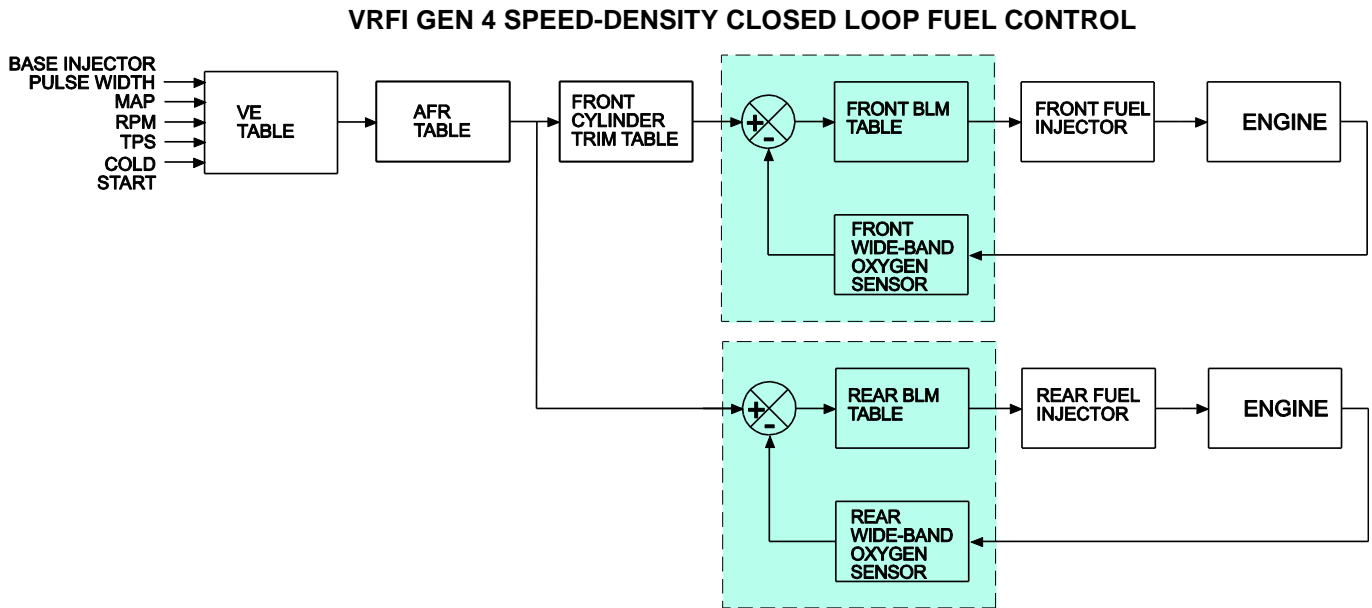

Injector pulse widths are calculated based on the following equations:

$$\text{Front Injector PW} = \text{Base PW} \times \text{CF} \times \text{Front CSE} \times (\text{MAP}/300) \times \text{VE} \times (14.7/\text{AFR}) \times \text{Front Cyl Trim} \times \text{Front BLM}$$

$$\text{Rear Injector PW} = \text{Base PW} \times \text{CF} \times \text{Rear CSE} \times (\text{MAP}/300) \times \text{VE} \times (14.7/\text{AFR}) \times \text{Rear BLM}$$

Where:

Front Injector PW	Injector pulse width (milliseconds)
Rear Injector PW	
Base PW	Base injector pulse width (milliseconds)
CF	Correction factor (air temperature and battery voltage)
Front CSE	Cold start fuel enrichment (percent). There are independent front and rear cold start enrichment tables
Rear CSE	
MAP	Manifold absolute pressure (kPa)
VE	Volumetric efficiency table (percent)
AFR	Air/fuel ratio (numeric AFR value)
Front BLM	Block learn multiplier tables (closed loop correction factor as percent)
Rear BLM	
Front Cyl Trim	Front cylinder trim table (percent)

The calculated base injector pulse width (refer to Appendix B) is corrected for cold start enrichment, intake air temperature (IAT), and battery voltage. The corrected value is then multiplied by the VE table value to determine the theoretical injector pulse width for a 14.7 air fuel ratio. This value is then multiplied by the AFR table to arrive at the desired air/fuel ratio. A feedback correction is applied based on the oxygen sensor signal and the stored closed loop correction values in the block learn multiplier (BLM) table.

APPENDIX B – FUEL CALCULATOR SPREADSHEET

The fuel calculator spreadsheet shown below is available for download from our website in the form of an Excel spreadsheet. The calculator spreadsheet is used to verify that the selected fuel system will be adequate for the intended engine power level. The spreadsheet also calculates the base injector pulse width that is required as an overall scale factor for program setup.

TCFI/VRFI Fuel Calculator for 300 kPa Speed-Density Systems

Input Values

Engine Horsepower (at Max Boost)	300
Maximum RPM	9000
Maximum Boost Pressure (PSI Absolute) Note 1	41.0
Target Lambda (at Max Boost/Wide Open Throttle) Note 2	0.75
BSFC (Brake Specific Fuel Consumption lbs/HP-hr) Note 2	0.67
Injector Flow Rating (lbs/hr)	120
Number of Injectors	2
Injector Rated Pressure (PSI) Note 3	43.5
Actual System Pressure (PSI) Note 3	58

Calculated Values

Maximum Fuel Requirement (lbs/hr)	246
Available Fuel at 80% Injector Duty Cycle (lbs/hr)	222
Base Injector Pulsewidth (msec) Note 4	9.6
Expected Duty Cycle at Maximum Condition (%) Note 5	89%

Notes:

1. Maximum boost pressure is absolute pressure, not gauge pressure difference above atmospheric
2. Typical values for maximum power at wide open throttle (BSFC values are at approximately .92 Lambda)

Fuel Type	BSFC	Lambda
Gasoline	.45	.85-.87
E10	.47	.85-.87
E70	.62	.71-.75
E85	.67	.71-.75
E100	.73	.71-.75

3. Fuel injectors rated are at differential pressure across the injectors. Industry standard ratings are at 43.5 psi. Harley rates injectors at actual operating pressure of 58 psi. To convert from gm/sec to lbs/hour, multiply by 7.93. A fuel pressure regulator, referenced to manifold pressure, is required for all boosted applications. Please contact our tech support for details.

4. Base injector pulsewidth is used by the PC Link program to establish overall fuel scaling and is entered under Module Parameters.

5. Expected duty cycle at maximum condition is the value at maximum boost pressure and RPM and target lambda value.